

AGRI PLUS GD

DIECI AGRI PLUS TELEHANDLER 4.2T / 7 M - TIER 4



42.7

DIECI
AUSTRALIA

PERFORMANCE

Machine model	AGRI PLUS 42.7 VS EVO2 - GD
Maximum capacity	4200 kg
Maximum lifting height on wheels	6.90 m
Maximum horizontal extension on wheels	3.75 m
Fork swiveling angle	146°
Pull-out force	6000 daN
Towing force	8200 daN
Maximum climb angle	60%
Unladen weight	8500 kg
Max speed (referred to wheels with maximum permitted diameter)	41.7 km/h

BOOM

Machine model	AGRI PLUS 42.7 VS EVO2 - GD
Lifting	6.3 s
Getting off the basket	3.7 s
Extension	3.7 s
Retraction	2 s
Forward swiveling	2.1 s
Reverse swiveling	1.3 s

ENGINE

Machine model	AGRI PLUS 42.7 VS EVO2 - GD
Brand	FPT
Nominal power	103 kW (125 HP) @ 2200 rpm
Max Power	114 kW (153 HP) @1800 rpm
Operation	4-stroke
Injection	Electronic, common rail
Number and arrangement of cylinders	4, Vertical in line
Displacement	4485 cm ³
Consumption	205.9 g/kWh
@rpm	1800rpm
Emission standards	Stage IV / Tier 4F
Cooling system	Liquid
Intake	Turbo compressor after-cooler

DIFFERENTIAL AXLES

Machine model	AGRI PLUS 42.7 VS EVO2 - GD
Axles types	2 steering, with 4 epicycloidal reduction gears
Type of steering	4 wheels / transversal / 2 wheels
Front axle	Rigid
Rear axle	Swinging
Service brake	Oil bath with servo brake on front and rear axle with double hydraulic system
Park brake	Negative Actuation with electronic control

HYDRAULIC SYSTEM

Machine model	AGRI PLUS 42.7 VS EVO2 - GD
Hydraulic pump type	Gear pump for power steering, movements, fan drive and automatic fan reversal
Hydraulic pump capacity	230 L/min
Max. operating pressure	25.5 MPa (3698 psi)
Distributor control	4in1 proportional Joystick with FNR

REFUELING

Machine model	AGRI PLUS 42.7 VS EVO2 - GD
Hydraulic motor (total)	160.0 L
Diesel tank	175.0 L (47.55 gal)
AdBlue tank	35.0 L

TRANSMISSION

Machine model	AGRI PLUS 42.7 VS EVO2 - GD
Transmission type	Hydrostatic single speed Vario system EVO2 with electronic control
Reversal	With electronic control operated with vehicle in motion
Inching	With electronic pedal for controlled forward movement
Drive Mode	Automotive, Eco, Loader, Creeper

TYRES

Machine model	AGRI PLUS 42.7 VS EVO2 - GD
Standard tyres	460-70R 24"

DIMENSIONS

Machine model	AGRI PLUS 42.7 VS EVO 2 - GD
A	360 mm
B	1382 mm
C	2850 mm
D	971 mm
E1	2630 mm
F	4452 mm
G	5203 mm
H	2410 mm
I	960 mm
K01	33°
K03	9°
K06	144°
K07	16°
K08	131°
L	1870 mm
L1	5375 mm
M	2290 mm
M1	1554 mm
N1	1755 mm
O1	6403 mm
P	1099 mm
Q	3753 mm
R1	1100 mm
S1	120 mm
T1	4887 mm
U1	3787 mm
V1	8892 mm
P1	50 mm
Q1	1200 mm

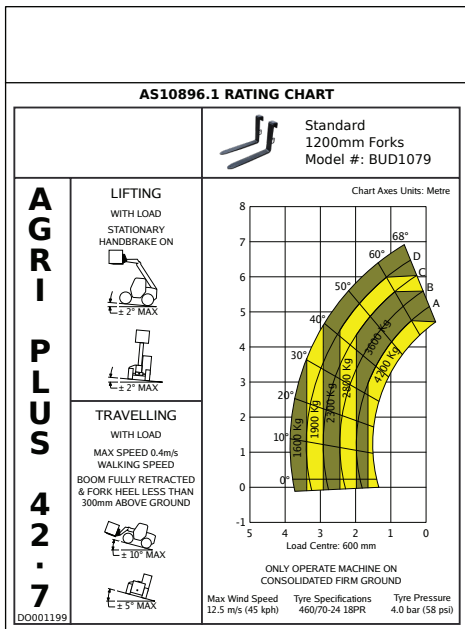
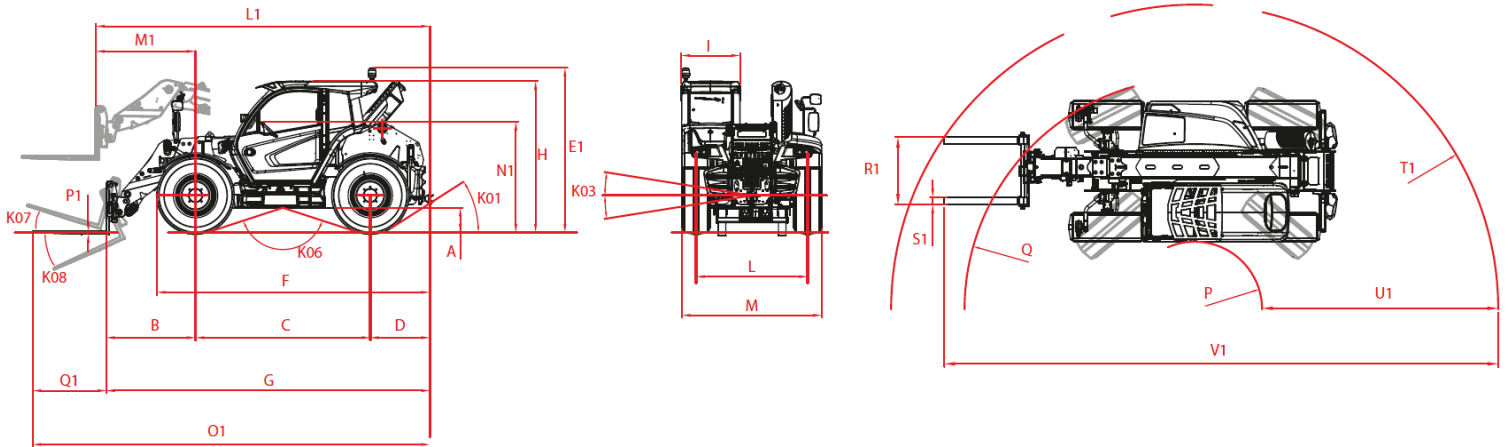



Distributed by Dieci Australia and their network of authorised dealers.

Unit 1/5 Melito Court, Prestons NSW 2170
www.dieciaustralia.com.au | info@dieciaustralia.com.au
Tel. +61 2 8795 4555

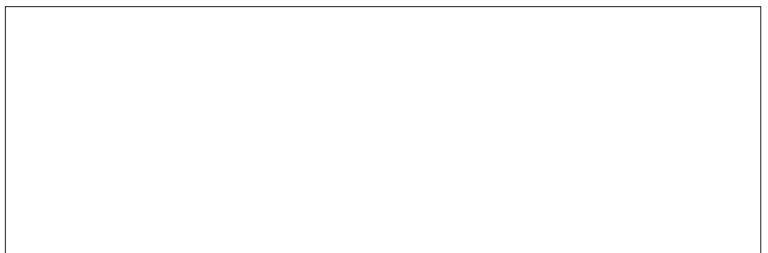

Illustrations and photos show the standard international models and may or may not include optional equipment, accessories, customer installed or modified parts, optional parts and all standard equipment with some differences in colour and features. Machine specifications are subject to change without notice and additional load charts and machine or attachment specifications may be available on request. Please refer to the operators manual for correct machine and attachment operation.

Printed in Australia SKT Agri Plus EXTRA-EC-AU | 1.1 2020